



Cambridge IGCSE[®]

DESIGN & TECHNOLOGY

0445/05

Paper 5 Graphic Products

For examination from 2020

MARK SCHEME

Maximum Mark: 50

Specimen

This document has **6** pages. Blank pages are indicated.

Generic Marking Principles

These general marking principles must be applied by all examiners when marking candidate answers. They should be applied alongside the specific content of the mark scheme or generic level descriptors for a question. Each question paper and mark scheme will also comply with these marking principles.

GENERIC MARKING PRINCIPLE 1:

Marks must be awarded in line with:

- the specific content of the mark scheme or the generic level descriptors for the question
- the specific skills defined in the mark scheme or in the generic level descriptors for the question
- the standard of response required by a candidate as exemplified by the standardisation scripts.

GENERIC MARKING PRINCIPLE 2:

Marks awarded are always **whole marks** (not half marks, or other fractions).

GENERIC MARKING PRINCIPLE 3:

Marks must be awarded **positively**:

- marks are awarded for correct/valid answers, as defined in the mark scheme. However, credit is given for valid answers which go beyond the scope of the syllabus and mark scheme, referring to your Team Leader as appropriate
- marks are awarded when candidates clearly demonstrate what they know and can do
- marks are not deducted for errors
- marks are not deducted for omissions
- answers should only be judged on the quality of spelling, punctuation and grammar when these features are specifically assessed by the question as indicated by the mark scheme. The meaning, however, should be unambiguous.

GENERIC MARKING PRINCIPLE 4:

Rules must be applied consistently e.g. in situations where candidates have not followed instructions or in the application of generic level descriptors.

GENERIC MARKING PRINCIPLE 5:

Marks should be awarded using the full range of marks defined in the mark scheme for the question (however; the use of the full mark range may be limited according to the quality of the candidate responses seen).

GENERIC MARKING PRINCIPLE 6:

Marks awarded are based solely on the requirements as defined in the mark scheme. Marks should not be awarded with grade thresholds or grade descriptors in mind.

Mark scheme key

- The symbol / separates alternative answers that could be given for the same mark(s).
- Square brackets around a number show partial marks that can be awarded.
- Square brackets around text show extra information not needed for the mark(s) to be awarded.

Question	Answer	Marks
1(a)	Cup outline – Trapezium 130 high × 60 base [1] Two diagonal lines for side of crown [1] Two semi-circles Ø40 [1]	3
1(b)	Octagon: Outside square 60 × 60 constructed [1] Four quarter-circles (one from each corner) intersecting in centre [1] Eight sides drawn to complete bottom of outline [1] Horizontal line 25 mm above base of octagon [1] Arcs R20 drawn [1]	5

Question	Answer	Marks
2	Height 210 [1] Width 140 [1] Central position – 20 mm top, bottom and either side [1]	3

Question	Answer	Marks
3(a)	<u>Plan</u> Square outline 100 × 100 [1] Three radiused corners R30 [3 × 1 mark] Three circles R17 (1) correct centre point [1] Handle outline 60 × 30 [1] Radiused corner R5 [1] <u>Side view</u> Rectangular outline 160 × 5 [1] Hidden detail lines dotted [1]	10

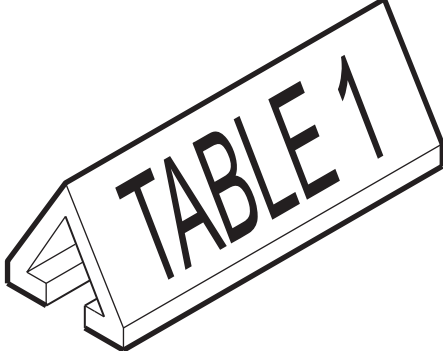
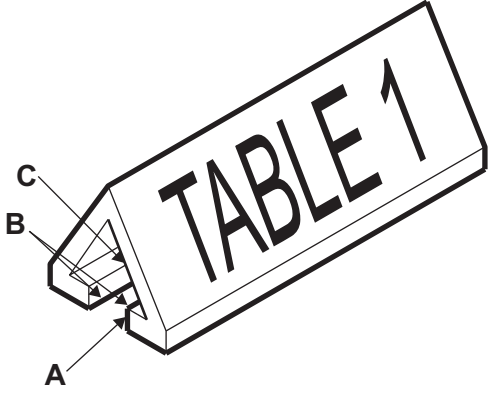
Question	Answer	Marks
3(b)	<p>Thick lines: Outside outline [1]</p>  <p>Vertical front inner edge – A [1] Two long inner edges – B [1] Sloping inside front edge – C [1]</p> 	4

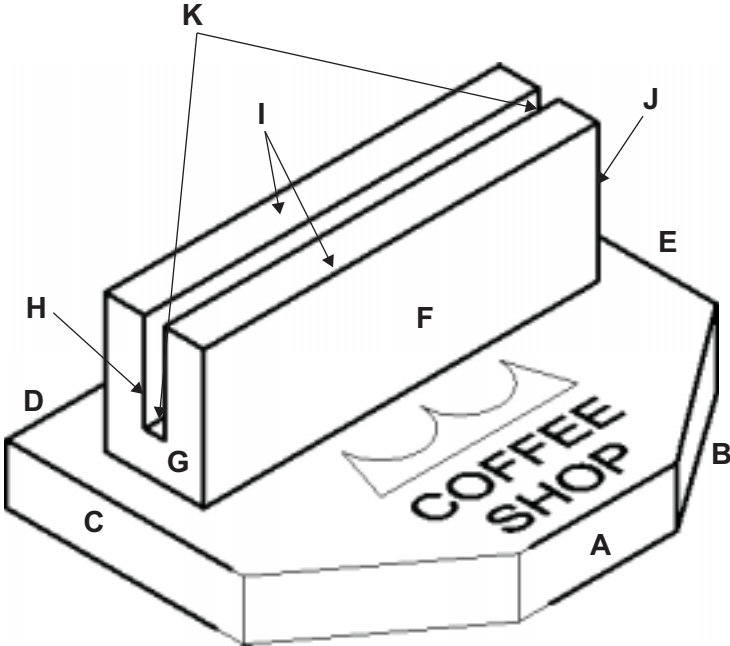
Question	Answer	Marks
EITHER		
4(a)	Major axis 60 mm [1] Minor axis 40 mm [1] Some construction [1] OR clear construction [2] Six or fewer points plotted [1] OR seven or more points plotted [2] Ellipse profile correct to overlay [1]	7
4(b)(i)	Hand width / palm width / hand length / span [1] Finger width / finger size / size of 2 or 3 fingers [1]	2
4(b)(ii)	To determine length/height of the handle [1] To determine distance away from the cup [1]	2
4(c)	The colour will change [1] due to the heat of the coffee [1]. [Guidance: wording will vary but award 1 mark for colour of the design changing and 1 mark for identifying that it is the heat that causes the change in colour.]	2
4(d)	 <p data-bbox="304 1496 914 1879"> Front face of base side – A [1] Angled right side of base – B [1] Left side of base – C [1] Base top back edge – D [1] Base right side top edge – E [1] Front face of upstand – F [1] End side of upstand 35 × 25 – G [1] Inside cut out on end of upstand 25 × 5 – H [1] Both top edges of upstand – I [2 × 1 mark] Right side vertical edge of upstand – J [1] Inner lines of menu slot on upstand – K [1] </p>	12
OR		

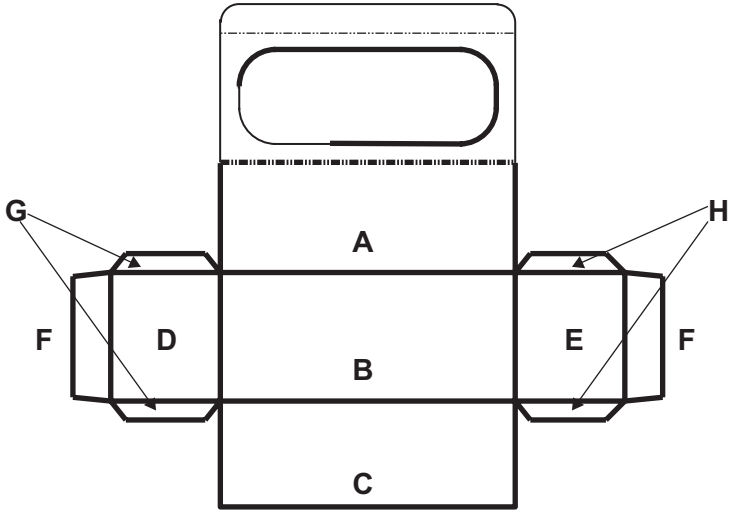
Question	Answer	Marks
5(a)(i)	 <p>Back of package – A [1] Base of package – B [1] Front of package – C [1] Left side – D [1] Right side – E [1] Rectangular top flap closers left and right – F [1] drawn with slight angle [1] as shown above Both flaps on left side – G [1] Both flaps on right side – H [1] Correct dotted/dashed lines used to show fold lines [1]</p>	10
5(a)(ii)	Length 70 mm [1] Width 25 mm [1] 5 mm distance from all edges [1] Three radiused corners R10 [1]	4
5(b)	1 – Craft knife / scalpel / scissors by hand [1] 40 – Laser cutter / plotter / vinyl cutter / CAMM1 [1] 8000 – Die cutter / press forme [1]	3
5(c)	Any two from: Universally understood / recognised all around world / understood in all languages / takes up less space / no need to print in multiple languages	2
5(d)	Four bars drawn [1] Scale used on the vertical axis [1] Labels used on the horizontal axis [1] One/two/three bars plotted correctly [1] OR four bars plotted correctly [2] Appropriate colour used to enhance the illustration [1]	6